

Prima

APS 10 D

Subwoofer
800 W



TECHNICAL SPECIFICATIONS		
Component		Subwoofer
Size	mm (in.)	250 (10)
Power Handling	W peak	800
	W continuous	400
Impedance	Ω	4 + 4
Centre to centre distance	mm (in.)	255 (10.04)
Midrange magnet size D x d x h	mm (in.)	140 (5.51) x 70 (2.76) x 30 (1.18)
Total driver displacement	l (cu.in.)	1,12 (0.02)
Hole diameter		5 (0.2)
Weight of one speaker	kg (lb.)	5,24 (11.56)
Magnet		High density flux ferrite
Cone		Water-repellent pressed paper
Subwoofer Voice Coil \varnothing	mm (in.)	60 (2.36)
*Xmech		± 18 (0.71)

ELECTRO-ACOUSTIC PARAMETERS		
D	mm	220
Xmax	mm	$\pm 12,6$
Re	Ω	2,2
Fs	Hz	27
Le	mH	1,5
Vas	l	41
Mms	g	170
Cms	mm/N	0,2
BL	T·m	10,4
Qts		0,52
Qes		0,58
Qms		4,7
Spl	dB	84

- 1 Ultra-low profile (4.7 in. / 120 mm) for maximum installation flexibility.
- 2 Designed to deliver maximum performance in a sealed enclosure starting from 10 lt.
- 3 Special designed cone-dustcap-basket geometry which guarantees a long linear excursion capability (11 mm, one-way) while keeping the mounting depth to minimum.
- 4 Air vents on the basket underneath the spider, eliminating the need for the central pole vent allowing mounting close to rear wall of enclosure.
- 5 Massive motor assembly, optimized with FEM (Finite Element Modeling) for perfect control under high power, high excursion conditions.
- 6 Water-repellent pressed paper 10 in. cone, featuring a profile developed with FEM simulation and optimized with the Klippel Scan Vibrometer.
- 7 Dual voice coil design specifically developed to be combined with either AP8.9 bit (2 CH + 2 CH bridged), AP5.9 bit (Sub CH) or AP4.9 bit/AP4 D (2 CH bridged) amplifiers.
- 8 Steel mesh grille and plastic gasket included.

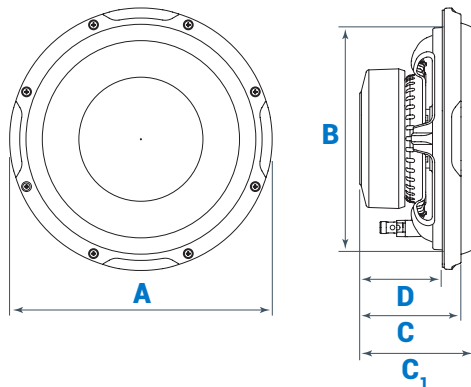
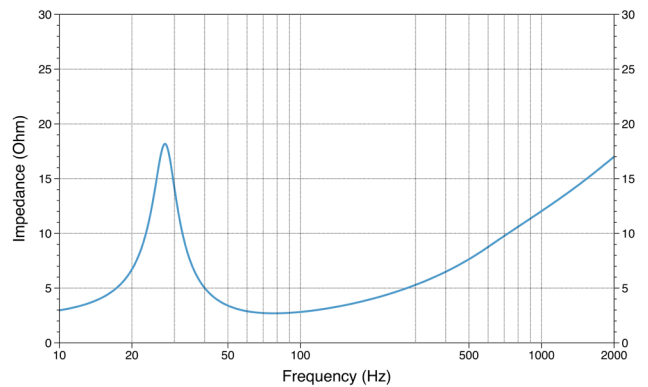

A	B	C	C ₁	D
270 mm	233 mm	105 mm	119 mm	88 mm
10.63 in.	9.17 in.	4.13 in.	4.69 in.	3.46 in.

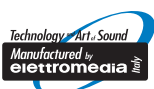

Elettromedia
62018 Potenza Picena (MC) Italy
T +39 0733 870 870 - F +39 0733 870 880
elettromedia.com

